



C7 RF Transceiver Module

FEATURES

- 78 selectable RF channels (2403 to 2480 MHz)
- 20mm x 20mm drop-in module with F antenna
- Ultra low power operation
- Simple sync/async serial interface
- Programmable output power up to +4 dBm
- Excellent receiver sensitivity -86 dBm
- 1 Mbps RF data rate, GFSK modulation
- Up to 8 ANT channels
- Broadcast, acknowledged, or burst data transmissions
- Built-in ANT-FS (file share) with AES-128 encryption
- ANT channel combined message rate up to 200Hz (8byte data payload)
- Minimum message rate per ANT channel 0.5Hz
- Burst transfer rate up to 20Kbps (true data throughput)
- Up to 3 public, managed and/or private network keys
- High resolution proximity pairing and RSSI reading
- 2 V to 3.6V supply voltage range
- -40°C to +85°C operating temperature
- Pin compatible with ANT AP2, AT3 and AP1 modules
- Radio regulatory approval for major markets
- RoHS compliant



APPLICATIONS

Network controllers and data hubs.
Complex sensors in health and fitness

FAMILY MEMBERS

ANTC782M5IB – 8 ANT channels; Molex Connector
ANTC782M4IB – 8 channels, surface mount

ANT NETWORK CONFIGURATIONS

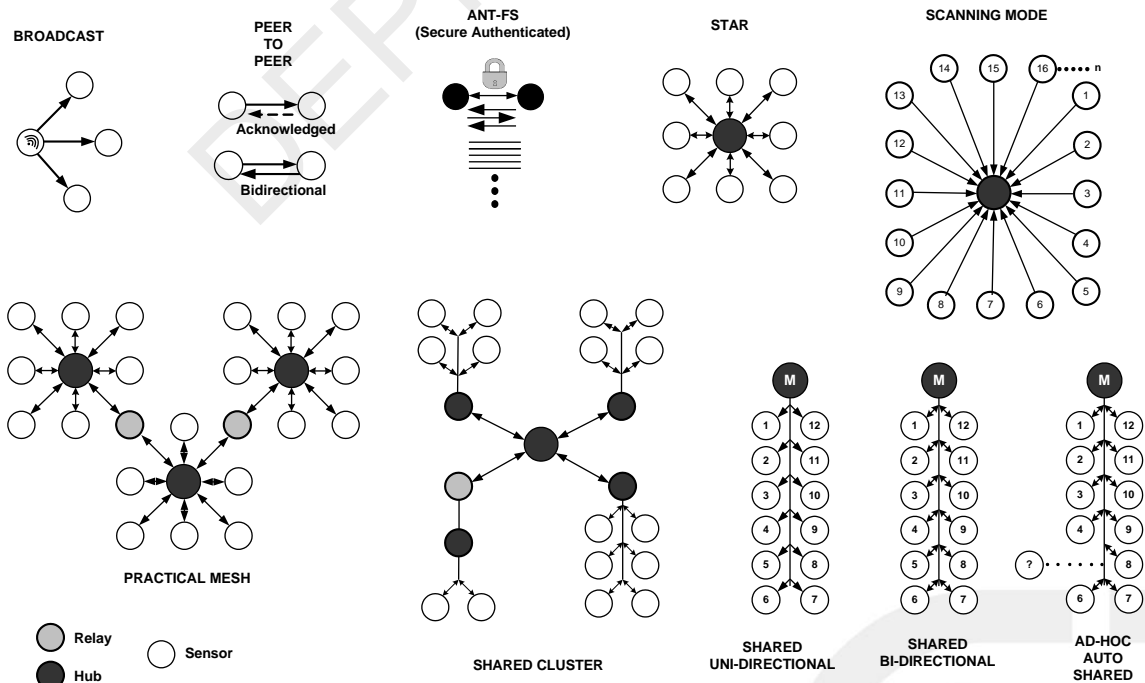

D0001445 Rev 1.3

Table of Contents

1. ANT C7 Module	5
1.1 Production Code	5
1.2 Interface	6
1.3 Application MCU connection	7
1.3.1 Async Mode	7
1.3.2 Byte Sync Mode	8
1.3.3 Bit Sync Mode	9
1.3.4 External Memory Connection	10
1.4 Mounting Guideline	10
1.5 Reflow Guideline	10
1.6 Pick-n-Place	10
2. Regulatory Approval	11
2.1 United States	11
2.2 Industry Canada Compliance	11
2.3 CE Declaration of Conformity	12
2.4 Australia & New Zealand	12
2.5 Japan	12
3. Electrical Specifications	13
3.1 Absolute Maximum Ratings ⁽¹⁾	13
3.2 Recommended Operating Conditions	13
3.3 ELECTRICAL CHARACTERISTICS	13
3.4 RF Characteristics	14
3.5 Application Specific Power Usage	15
3.6 Calculating the Average Current Consumption and Battery Life	16
4. Mechanical Drawings	18
5. Technical Support	23
5.1 ANT Forum	23
5.2 Public Technical References	23
5.3 ANT Developer's Zone	23
5.4 ANT Social Media	23

Notices and Restricted Use Information

Information contained in this document is provided only for your ("Customer" or "you") convenience and may be superseded by updates. It is your responsibility to ensure that your application meets with your specifications.

Dynastream Innovations Inc. ("DYNASTREAM") makes no representations or warranties of any kind whether express or implied, written or oral, statutory or otherwise, related to the information, including but not limited to its condition, quality, performance, merchantability or fitness for purpose. DYNASTREAM disclaims all liability arising from this information and its use.

DYNASTREAM does not assume any responsibility for the use of the described ANT RF module ("the Module(s)"). Dynastream makes no representation with respect to the adequacy of the module in low-power wireless data communications applications or systems. Any Products using the Module must be designed so that a loss of communications due to radio interference or otherwise will not endanger either people or property, and will not cause the loss of valuable data. DYNASTREAM assumes no liability for the performance of products which are designed or created using the Modules.

The Modules are not designed, intended, or authorized for use as components in systems intended for surgical implant into the body, or other applications intended to support or sustain life, or for any other application in which the failure of the Module could create a situation where personal injury or death may occur. If you use the Modules for such unintended and unauthorized applications, you do so at your own risk and you shall indemnify and hold DYNASTREAM and its officers, employees, subsidiaries, affiliates, and distributors harmless against all claims, costs, damages, and expenses, and reasonable attorney fees arising out of, directly or indirectly, any claim of personal injury or death associated with such unintended or unauthorized use, even if such claim alleges that DYNASTREAM was negligent regarding the design or manufacture of the Product.

The information disclosed herein is the exclusive property of DYNASTREAM, and is not to be reproduced and/or distributed without the written consent of DYNASTREAM. No part of this publication may be reproduced or transmitted in any form or by any means including electronic storage, reproduction, execution or transmission without the prior written consent of DYNASTREAM. The recipient of this document by its retention and use agrees to respect the security status of the information contained herein.

DYNASTREAM believes the information contained herein is correct and accurate at the time of its release. However, the information contained in this document is subject to change without notice and should not be construed as a commitment by DYNASTREAM unless such commitment is expressly given in a covering document.

©2014 Dynastream Innovations Inc. All Rights Reserved. ANT is a registered trade mark of Dynastream Innovations Inc.

ANT™ Overview

ANT™ is a practical wireless sensor network protocol running on 2.4 GHz ISM band. Designed for ultra low power, ease of use, efficiency and scalability, ANT easily handles peer-to-peer, star, tree and practical mesh topologies. ANT provides reliable data communications, flexible and adaptive network operation and cross-talk immunity. The protocol stack of ANT is extremely compact, requiring minimal microcontroller resources and considerably reducing system costs.

ANT provides carefree handling of the Physical, Network, and Transport OSI layers. In addition, it incorporates key low-level security features that form the foundation for user-defined, sophisticated, network-security implementations. ANT ensures adequate user control while considerably lightening the computational burden in providing a simple yet effective wireless networking solution.

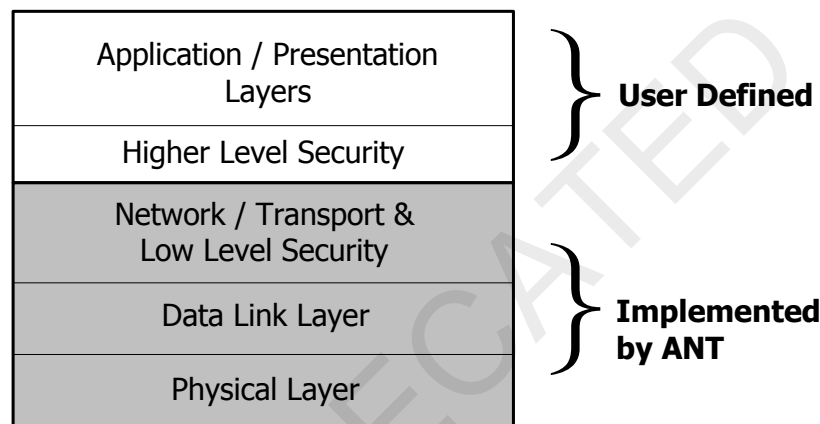

ANT supports public, managed and private network architectures with 2^{32} uniquely addressable devices possible, ensuring that each device can be uniquely identified from each other in the same network.

ANT is proven with an installed base of over multimillion nodes in ultra low power sensor network applications in sport, fitness, home and industrial automation. The ANT solutions are available in chips, chipsets and modules to suit a wide variety of application needs.

The complete description of ANT message protocol is found in the document "ANT Message Protocol and Usage". The serial interface details are provided in the document "Interfacing with ANT General Purpose Chipsets and Modules". Both documents are available on www.thisisant.com.

ANT+ and ANT+ Alliance

ANT+ is the open application layer on the top of the ANT stack. It standardizes communications and facilitates interoperability between a wide array of personal sports, wellness and lifestyle monitoring devices. ANT+ defines device profiles that specify access, data formats, and channel parameters.

The ANT+ Alliance is comprised of companies who have adopted the ANT+ promise of interoperability. The Alliance ensures standardized communication through optimized brand value and partnerships with other top tier companies and products.

1. ANT C7 Module

The ANT C7 module is a drop-in module using the CC2571, an ANT network processor from Texas Instruments. The chip is able to support up to 8 independent ANT channels and for the first time offers the following features embedded:

- Integrated ANT File Share (ANT-FS) functions for exchanging data records
- AES-128 data encryption on file transfers
- Maximum +4dBm transmission power
- High resolution RSSI reading

An F PCB antenna being integrated on the small-sized 20mm by 20mm board, the module has been certified to comply with radio regulation or standards covering global markets include North America, Europe, Australia and New Zealand.

The ANT C7 module eases the burden of extensive RF design and regulatory compliance testing for application and system developers, allowing quicker time to market. The module is ideally suited for control or hub nodes of a wireless sensor network.

Incorporated in the C782MxIB module product family are several new generation ANT core stack enhancements:

- Background scanning
- Continuous scanning mode
- High density node support
- Improved channel search
- Channel ID management
- Improved transmission power control
- Frequency agility
- Proximity acquisition

The C782MxIB module is useful for chip evaluation of both CC2570 and CC2571 from Texas Instruments.

The C7 modules are currently available in the following varieties.

Module	ANT chip Used	Description	Packaging Option
ANTC782M4IB	CC2571	Surface mountable, 8 ANT channels, 20x20mm, industrial temperature range	Tray: 20 modules on a tray Reel: 800 modules taped on a 13" reel
ANTC782M5IB	CC2571	With Molex connector, 8 ANT channels, 20x20mm, industrial temperature range	Tray: 20 modules on a tray

1.1 Production Code

For technical support and customer service purposes, a production code of six characters is printed on the product sticker as illustrated below.



1.2 Interface

The module may be connected to the user's host controller using the 17 pin-out assignment (surface mount) style or the 20-pin Molex header connection style provided below:

Surface Mount Pin	Molex Header Pin	Pin Name	Async Mode	Sync Mode	Description
1	6	EE_GND*	EEPROM GND	EEPROM GND	GND for external EEPROM
2	10	$\overline{\text{RST}}$	$\overline{\text{RST}}$	$\overline{\text{RST}}$	Reset the device
3	1	Vcc	Vcc	Vcc	Power supply source
4	19	GND	GND	GND	Power supply ground
5	8	EE_MISO*	EEPROM MISO	EEPROM MISO	MISO for external EEPROM
6	17	$\overline{\text{SUSPEND}}$ / $\overline{\text{SRDY}}$	$\overline{\text{SUSPEND}}$	$\overline{\text{SRDY}}$	Async -> Suspend control Sync -> Serial port ready
7	15	SLEEP/ $\overline{\text{MRDY}}$	SLEEP	$\overline{\text{MRDY}}$	Async -> Sleep mode enable Sync -> Message ready indication
8	13	EE_CS*	EEPROM Chip Select	EEPROM Chip Select	Chip Select for External EEPROM
9	11	PORTSEL	PORTSEL (Tie to GND)	PORTSEL (Tie to Vcc)	Asynchronous or synchronous port select
10	7	BR2/SCLK	BR2	SCLK	Async -> Baud rate selection Sync -> Clock output signal
11	4	TXD0/SOUT	TXD0	SOUT	Async -> Transmit data signal Sync -> Data output
12	3	RXD0/SIN	RXD0	SIN	Async -> Receive data signal Sync -> Data input
13	5	BR1/SFLOW	BR1	SFLOW	Async -> Baud rate selection Sync -> Bit or byte flow control select
14	9	BR3	BR3	SPEEDSEL	Async -> Baud rate selection Sync -> Speed selection
15	14	EE_CLK*	EEPROM clock	EEPROM clock	Clock for External EEPROM
16	12	EE_MOSI*	EEPROM MOSI	EEPROM MOSI	MOSI for external EEPROM
17	2	RTS/SEN	RTS	SEN	Async -> Request to send Sync -> Serial enable signal
	16,18,20	NC	NC	NC	No connection

* Note: Leave these pins not connected if EEPROM is not present.

The speed of the byte-Sync mode can be set to either 500KHz or 4MHz by setting SPEEDSEL. Please refer to the table below.

SPEEDSEL	Byte-Sync Speed
0	500KHz
1	4MHz

The baud rate of the asynchronous communication is controlled by the speed select signals BR1, BR2 and BR3. Please refer to the table below.

BR3	BR2	BR1	Baud Rate
0	0	0	4800
1	0	1	9600
0	1	0	19200
0	0	1	38400
0	1	1	50000
1	1	1	57600
1	0	0	115200

1.3 Application MCU connection

Please refer to "Interfacing with ANT General Purpose Chipsets and Modules" and "CC2571 Datasheet". The following sample designs show the proper electrical connectivity of an ANT C7 module to an application microcontroller, using TI MSP430F1232 as example.

1.3.1 Async Mode

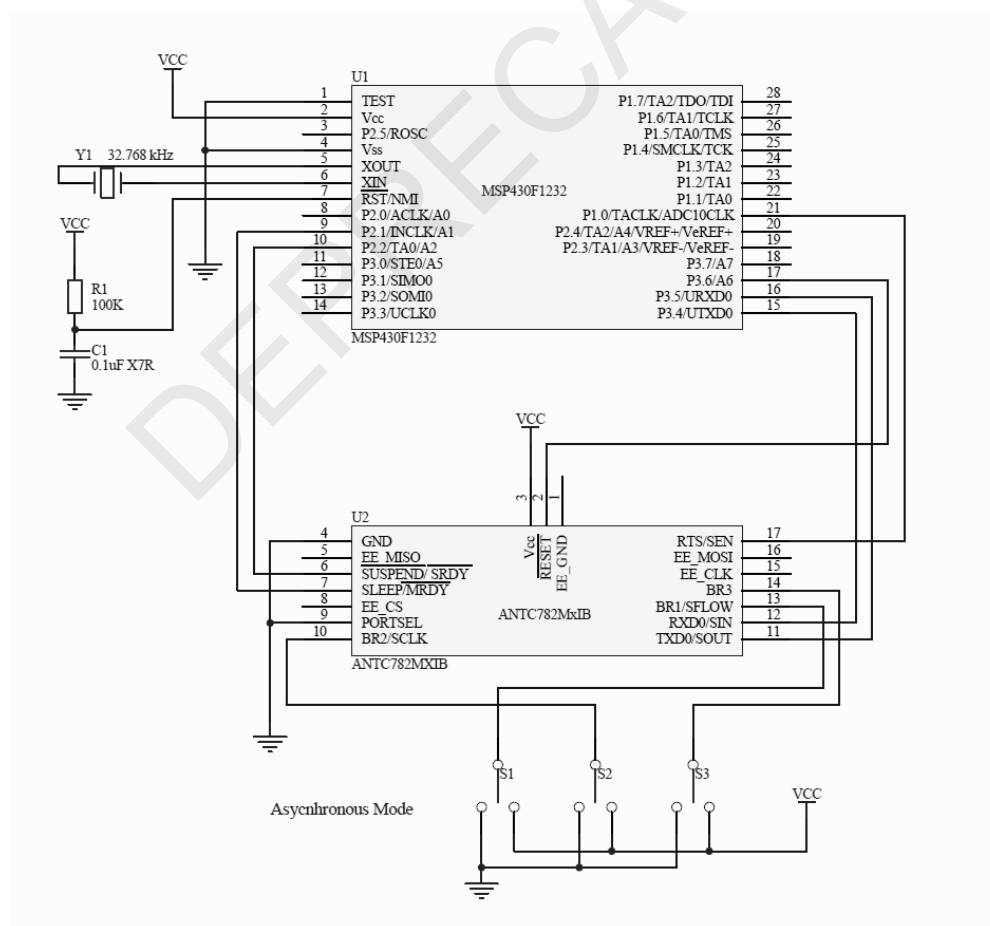

Notes:

- Module RXD and TXD connected directly to hardware USART of microcontroller.

- Switches on baud rate selection pins (BR1, BR2 and BR3) are for ease of use only. They can be connected directly to the logic level of interest.
- RTS can be connected to an interrupt pin for convenience in some applications. (Interrupt pins located on Port 1&2 on the MSP430F1232)

1.3.2 Byte Sync Mode

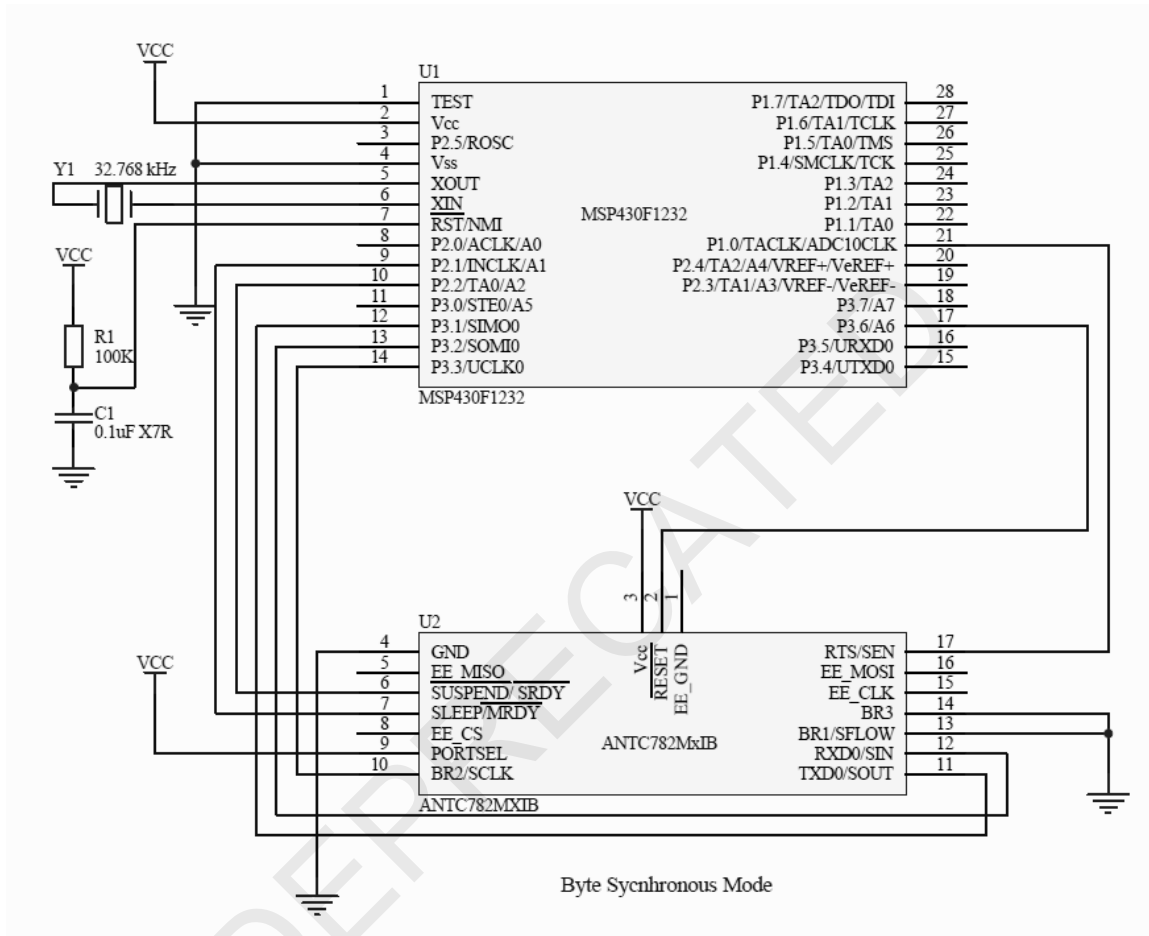

Notes:

- Module SOUT, SIN, and SCLK connected directly to hardware USART of microcontroller.
- SEN needs to be on an interrupt capable I/O pin on the microcontroller. (Interrupt pins located on Port 1&2 on the MSP430F1232)

1.3.3 Bit Sync Mode

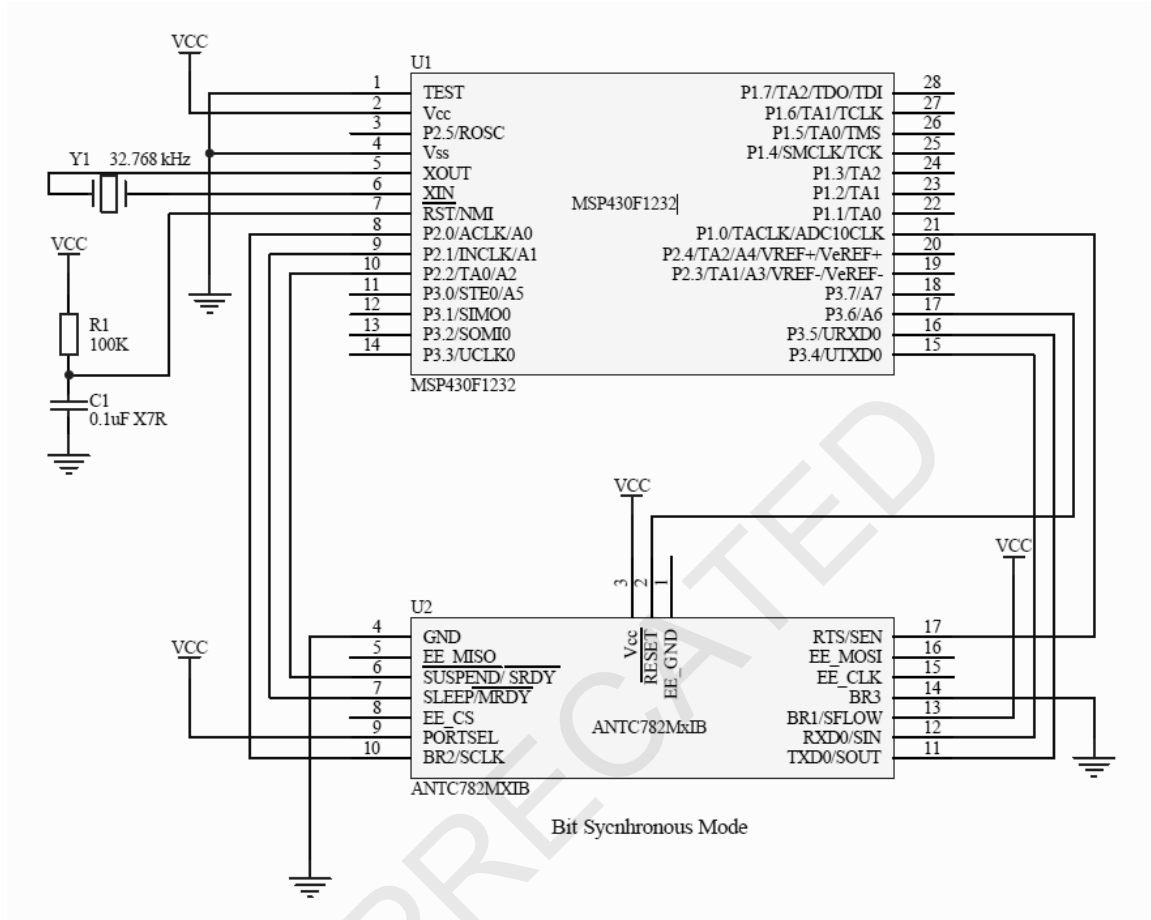

Notes:

- All interface signals are connected directly to I/O pins on the microcontroller.
- SCLK and SEN need to be on an interrupt capable I/O pin on the microcontroller. (Interrupt pins located on Port 1&2 on the MSP430F1232)

1.3.4 External Memory Connection

The ANT C7 has ANT-FS Client functionality embedded directly on the module. This includes the over-the-air ANT-FS protocol extension and the required file system utilities to manage stored data in non-volatile storage. An external EEPROM can be directly connected to the C7 module. Raw files can be sent and managed by the C7 module and downloaded over ANT-FS as desired. The diagram below depicts how to connect an external EEPROM to the C7 module. The connection is SPI. Please note that only EEPROM (not flash) is supported.

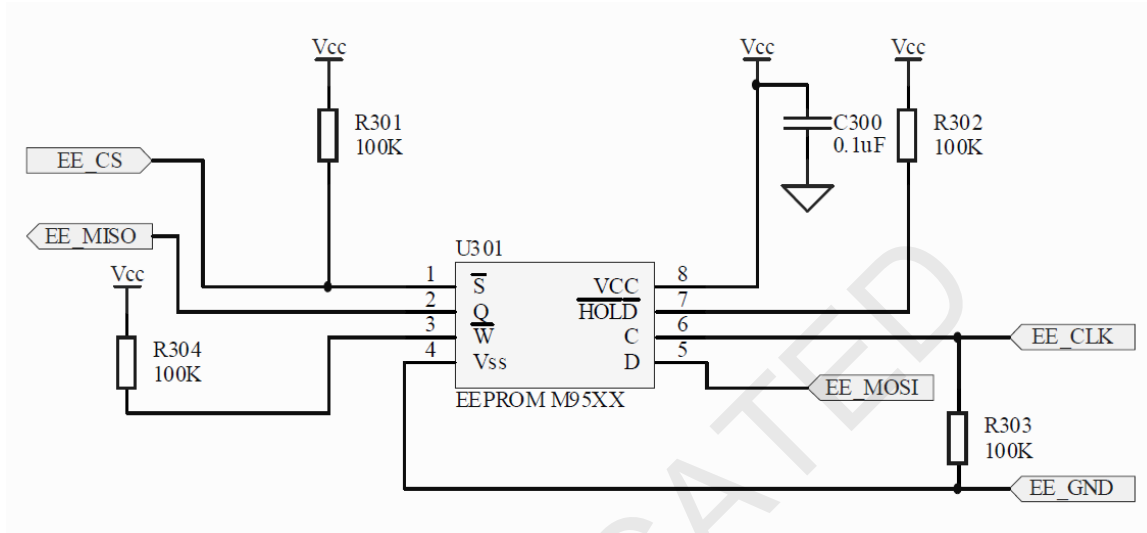

The file system and ANT-FS protocol are managed by using an extended version of the ANT/Host serial protocol. For complete details on how to use this protocol please consult the ANT document "FS_ANTFS Serial Message".

The extended Host/ANT interface uses a 2 byte message ID to identify FS and ANT-FS specific messages. The packet structure is detailed the "Integrated ANT-FS Interface Control" document".

1.4 Mounting Guideline

Refer to the recommended footprint drawing in section 4.

To connect to ANTC782M5IB, the mating socket to use is the Molex 52991-0208.

1.5 Reflow Guideline

ANTC7M4IB module is rated at moisture sensitive level 3 (MSL=3). To handle and use these modules, please follow the standard IPC/JEDEC J-STD-033B.1, "Handling, Packing, Shipping and Use of Moisture/Reflow Sensitive Surface Mount Devices".

To reflow, it is recommended that the peak solder joint/pad temperatures do NOT exceed 240°C. If possible, pre-heat the assembly within the oven profile for ~30 seconds at ~150 °C. Follow the solder paste manufacturer's recommendations, especially regarding temperature ramp rate and the time above liquidus.

1.6 Pick-n-Place

ANTC7M4IB module has the package option of 800 modules on a JEDEC standard 13" reel to facilitate machine pick and place.

2. Regulatory Approval

The ANT C7 module has received regulatory approvals in the United States (FCC) and Canada (IC), and has been verified to conform to the appropriate regulations in Europe, Australia and New Zealand. Such approvals allow the user to place the module inside a finished product and, in most cases, not require regulatory testing for an intentional radiator, provided no changes or modifications are made to the module circuitry. This does not preclude the possibility that some other form of authorization or testing may be required for the finished product. Changes or modifications could void the user's authority to operate the equipment. The end user must comply with all of the instructions provided by the Grantee, which indicate installation and/or operating conditions necessary for compliance.

2.1 United States

The ANT C7 module has been tested and found to comply with the limits for a Class B digital device, pursuant to Part 15 of the FCC Rules. These limits are designed to provide reasonable protection against harmful interference in a residential installation. This equipment generates, uses, and can radiate radio frequency energy and, if not installed and used in accordance with the instructions, may cause harmful interference to radio communications. However, there is no guarantee that interference will not occur in a particular installation. If this equipment does cause harmful interference to radio or television reception, which can be determined by turning the equipment off and on, the user is encouraged to try to correct the interference by one of the following measures:

- Reorient or relocate the receiving antenna.
- Increase the separation between the equipment and receiver.
- Connect the equipment into an outlet on a circuit different from that to which the receiver is connected.
- Consult the dealer or an experienced radio/TV technician for help.

The C7 module complies with Part 15 of the FCC Rules. Operation is subject to the following two conditions: (1) This device may not cause harmful interference, and (2) this device must accept any interference received, including interference that may cause undesired operation.

The C7 module does not contain any user-serviceable parts. Unauthorized repairs or modifications could result in permanent damage to the equipment, and void your warranty and your authority to operate this device under Part 15 regulations.

The C7 module is labelled with its own FCC ID, O6R1823 (note: First Character is the letter O, not the # 0.) If the FCC ID is not visible when the module is installed inside another device, then the outside of the device into which the module is installed must also display a label referring to the enclosed module. This exterior label can use wording such as the following: "Contains Transmitter Module FCC ID: O6R1823" or "Contains FCC ID: O6R1823". Any similar wording that expresses the same meaning may be used.

2.2 Industry Canada Compliance

This device complies with Industry Canada licence-exempt RSS standard(s). Operation is subject to the following two conditions: (1) this device may not cause interference, and (2) this device must accept any interference, including interference that may cause undesired operation of the device.

(Le présent appareil est conforme aux CNR d'Industrie Canada applicables aux appareils radio exempts de licence. L'exploitation est autorisée aux deux conditions suivantes : (1) l'appareil ne doit pas produire de brouillage, et (2) l'utilisateur de l'appareil doit accepter tout brouillage radioélectrique subi, même si le brouillage est susceptible d'en compromettre le fonctionnement.)

To comply with Industry Canada regulations, it is required that product containing the C7 module display a label referring to the enclosed module. This exterior label can use wording similar to the following: "Contains IC: 3797A-1823"

This information shall be affixed in such a manner as not to be removable except by destruction or defacement. The size of the lettering shall be legible without the aid of magnification but is not required to be larger than 8-point font size. If the device is too small to meet this condition, the information can be included in the user manual upon agreement with Industry Canada.

2.3 CE Declaration of Conformity

The C7 module is declared to be in conformance with the essential requirements and other relevant provisions of Directive 1999/5/EC and 2011/65/EU, as a low-powered unlicensed transmitter:

- EN 60950-1:2006+A11:2009+A1:2010 Information technology equipment - Safety - Part 1: General requirements
- EN 300 440-2 v1.4.1 Electromagnetic compatibility and Radio spectrum Matters (ERM); Short range devices; Radio equipment to be used in the 1 GHz to 40 GHz frequency range; Part 2: Harmonized EN covering the essential requirements of article 3.2 of the R&TTE Directive
- EN 61000-6-1:2007 Electromagnetic compatibility (EMC) -- Part 6-1: Generic standards - Immunity for residential, commercial and light-industrial environments
- EN 301 489-3 V1.4.1 Electromagnetic compatibility and Radio spectrum Matters (ERM); Electromagnetic Compatibility (EMC); standard for radio equipment and services; Part 3: Specific conditions for Short-Range Devices (SRD) operating on frequencies between 9 kHz and 40 GHz

2.4 Australia & New Zealand

The C7 module has been tested and found to comply with AS/NZS 4268:2008, Radio equipment and systems – Short range devices. The ACMA/MED supplier code number is N20233

2.5 Japan

The C7 module has been granted type certificate (mark number 203-JN6027). Standard applied:

Notification No. 88 of MIC 2004, 2.4GHz band wide-band low-power data communication system (item 19 of Article 2 paragraph 1)

3. Electrical Specifications

3.1 Absolute Maximum Ratings ⁽¹⁾

PARAMETER	TEST CONDITIONS	Min	Max	Unit
Supply voltage	All supply pins must have the same voltage	-0.3	3.9	V
Voltage on any digital pin		-0.3	VDD+0.3, ≤ 3.9	V
Input RF level			10	dBm
Storage temperature range		-40	85	°C
ESD	All pads, according to human-body model, JEDEC STD 22, method A114		2	kV
	According to charged-device model, JEDEC STD 22, method C101		500	V

(1) Stresses beyond those listed under Absolute Maximum Ratings may cause permanent damage to the device. These are stress ratings only and functional operation of the device at these or any other conditions beyond those indicated under Recommended Operating Conditions is not implied. Exposure to absolute-maximum-rated conditions for extended periods may affect device reliability.

3.2 Recommended Operating Conditions

Over operating free-air temperature range (unless otherwise noted)

PARAMETER	Min	Max	Unit
Operating ambient temperature range, T _A	-40	+85	°C
Operating supply voltage	2.0	3.6	V

3.3 ELECTRICAL CHARACTERISTICS

Measured with T_A = 25°C and V_{CC} = 3 V

PARAMETER	TEST CONDITIONS	Min	Typ	Max	Unit	
I – Current consumption	Peak RX current consumption		23.7		mA	
	Peak TX current consumption, -6 dBm output power		25.9		mA	
	Peak TX current consumption, 0 dBm output power		28.8		mA	
	Peak TX current consumption, +4 dBm output power		34.3		mA	
	Power-down current, 32 kHz oscillator active (Base)			1.0		µA
	Power-down current, 32 kHz oscillator disabled (Idle / Suspend)			0.5		µA

3.4 RF Characteristics

Measured with $T_A = 25^\circ\text{C}$ and $V_{CC} = 3\text{ V}$

PARAMETER	TEST CONDITIONS	Min	Typ	Max	Unit
RF frequency range	Programmable in 1 MHz steps	2400		2495	MHz
Data rate and modulation format	1 Mbps, GFSK, 160 kHz deviation				

Receive Section

1 Mbps, GFSK, 160-kHz deviation. Measured $T_A = 25^\circ\text{C}$, $V_{CC} = 3\text{ V}$, and $f_c = 2440\text{ MHz}$, unless otherwise noted.

PARAMETER	TEST CONDITIONS	Min	Typ	Max	Unit
Receiver sensitivity	0.1% BER		-86		dBm
Saturation			10		dBm
Co-channel rejection			-9		dB
Adjacent-channel rejection	$\pm 2\text{ MHz}$		23		dB
Alternate-channel rejection	$\pm 4\text{ MHz}$		39		dB
Frequency error tolerance ⁽¹⁾	Including both initial tolerance and drift	-150		150	kHz
Symbol rate error tolerance ⁽²⁾		-50		+50	ppm
Spurious emission. Only largest spurious emission stated within each band.	Conducted measurement with a 50 Ω single-ended load.		-70		dBm

(1) Difference between center frequency of the received RF signal and local oscillator frequency.

(2) Difference between incoming symbol rate and the internally generated symbol rate

Transmit Section

Measured with $T_A = 25^\circ\text{C}$, $V_{CC} = 3\text{ V}$, and $F_c = 2440\text{ MHz}$ unless otherwise noted.

PARAMETER	TEST CONDITIONS	Min	Typ	Max	Unit
Output power, maximum setting	Conducted measurement delivered to a single-ended 50 Ω load through a balun using maximum recommended output power setting.		4		dBm
Output power, minimum setting	Conducted measurement delivered to a single-ended 50 Ω load through a balun using minimum recommended output power setting.		-21		dBm
Programmable output power range	Delivered to a single-ended 50 Ω load through a balun.		25		dB
Spurious emissions,	Conducted measurement with a 50- Ω single-ended load.		-45		dBm

conducted	Complies with EN 300 328, EN 300 440 class 2, FCC CFR47, Part 15 and ARIB STD-T-66. ⁽¹⁾			
Average EIRP, Maximum setting	Radiated measurement with the module mated with ANTUIF ⁽¹⁾ board in an anechoic chamber at 2403 MHz.		-3.5	dBm

(1) ANT USB Interface board is provided in the ANTC7EK1 development kit

3.5 Application Specific Power Usage

State Specific Average Current

The table below lists the average current consumed while ANT is in specific states where a channel is not actively transmitting or receiving message.

Measured with $T_A = 25^\circ\text{C}$ and $V_{CC} = 3\text{ V}$

Symbol	Description	Value	Units
Base	Base current	1.0	μA
Idle	No active channels and no serial communication	0.5	μA
Suspend	SUSPEND activated in asynchronous serial mode	0.5	μA
Search	Active search on open channel	3.8	mA

The table below lists the average current per message as a function of the serial interface and message type. The message types are:

Average Current per Message

All current values in μA . Measured with $T_A = 25^\circ\text{C}$ and $V_{CC} = 3\text{ V}$. Output power set at 0dBm

Average Current Per Message	Transmit Broadcast ⁽¹⁾	Receive Broadcast ⁽²⁾	Transmit Acknowledged ⁽³⁾	Receive Acknowledged ⁽⁴⁾	Transmit-only Broadcast ⁽⁵⁾
I_{Sync_Byte}	49	31	70	42	27
I_{Sync_Bit}	130	94	146	107	127
I_{Async_57600}	55	34	73	44	37
I_{Async_50000}	57	38	81	51	39
I_{Async_38400}	59	41	84	54	44
I_{Async_19200}	75	55	95	64	66
I_{Async_9600}	116	84	134	97	107

I_{Async_4800}	119	141	222	149	189
-------------------------------	-----	-----	-----	-----	-----

- (1) Transmit Broadcast – Broadcast message transmitted over bi-directional master channel
- (2) Receive Broadcast – Broadcast message received by slave channel
- (3) Transmit Acknowledged – Acknowledged message transmitted over bi-directional master channel
- (4) Receive Acknowledged – Acknowledged message received by slave channel
- (5) Transmit-only Broadcast – Broadcast message transmitted by tx-only master channel

While these current values include the contribution of the radio and the serial interface they do not include the base (idle) current. To calculate the average current consumption of for a specific message rate please see the sample calculation below.

Average Burst Current

For practical purposes power consumption in burst mode is reported as an average current when bursting at a specific bit rate and using a specific serial interface. Please note that the bit rate of the burst is a function of the serial communication. The table below lists the continuous average current consumption while bursting.

Measured with T_A = 25°C and V_{CC} = 3 V. Output power set at 0dBm

Symbol	Description	Average Current	Units
I_{burst_20kbps_byte}	Continuous bursting at 20kbps in byte synch mode	9.0	mA
I_{burst_7.5kbps_bit}	Continuous bursting at 7.5kbps in bit synch mode	8.2	mA
I_{burst_20kbps_57600_async}	Continuous bursting at 20kbps in 57600 baud async mode	8.7	mA
I_{burst_20kbps_50000_async}	Continuous bursting at 20kbps in 50000 baud async mode	8.4	mA
I_{burst_13.8kbps_38400_async}	Continuous bursting at 13.8kbps in 38400 baud async mode	7.9	mA
I_{burst_8.4kbps_19200_async}	Continuous bursting at 8.4kbps in 19200 baud async mode	7.0	mA

3.6 Calculating the Average Current Consumption and Battery Life

The average current for a particular application will be a function of the message period, type and serial interface. By using the values listed in the tables above, the average current can be calculated using the following formula:

$$I_{AVE} = (I_{MSG} \times R_{MSG}) + I_{BASE}$$

where:

I_{AVE} – Average current consumption.

I_{MSG} – Current per message

I_{BASE} – Base current

For example, given an ANT node that transmits broadcast data over a bi-directional channel at 0.5Hz using a byte synchronous serial interface, the continuous average current can be calculated as follows:

$$I_{AVE} = (49 \times 0.5) + 1.0 = 25.5\mu A$$

To calculate the expected battery life of a system, the battery capacity and usage model must also be considered. The following formula can be used (please note that this considers the current consumed by the ANT part of the system only):

$$T_{BAT} = \frac{C_{BAT}}{(T_{Active} \cdot I_{Ave}) + (T_{Idle} \cdot I_{Idle})}$$

where:

T_{BAT} – Expected battery life of the system

C_{BAT} – Battery capacity

T_{Active} – Active time in transmit mode in a day

I_{Ave} – Average current consumption in active mode

T_{Idle} – Time in non-active mode (off) in a day

I_{Idle} – Average current in idle mode

For example, for a system using a CR2032 coin cell batter transmitting at 0.5Hz broadcast for 1 hour per day, the battery life of the system can be calculated as follows:

$$T_{BAT} = \frac{220mAh}{(1h \cdot 25.5\mu A) + (23h \cdot 0.5\mu A)} = 5945.95 \text{ days} = 16.3 \text{ years}$$

Please note that the above example assumes that 100% of the battery capacity can be dedicated to the ANT portion of the system.

An online power consumption estimator is provided at <http://www.thisisant.com/calculator>

4. Mechanical Drawings

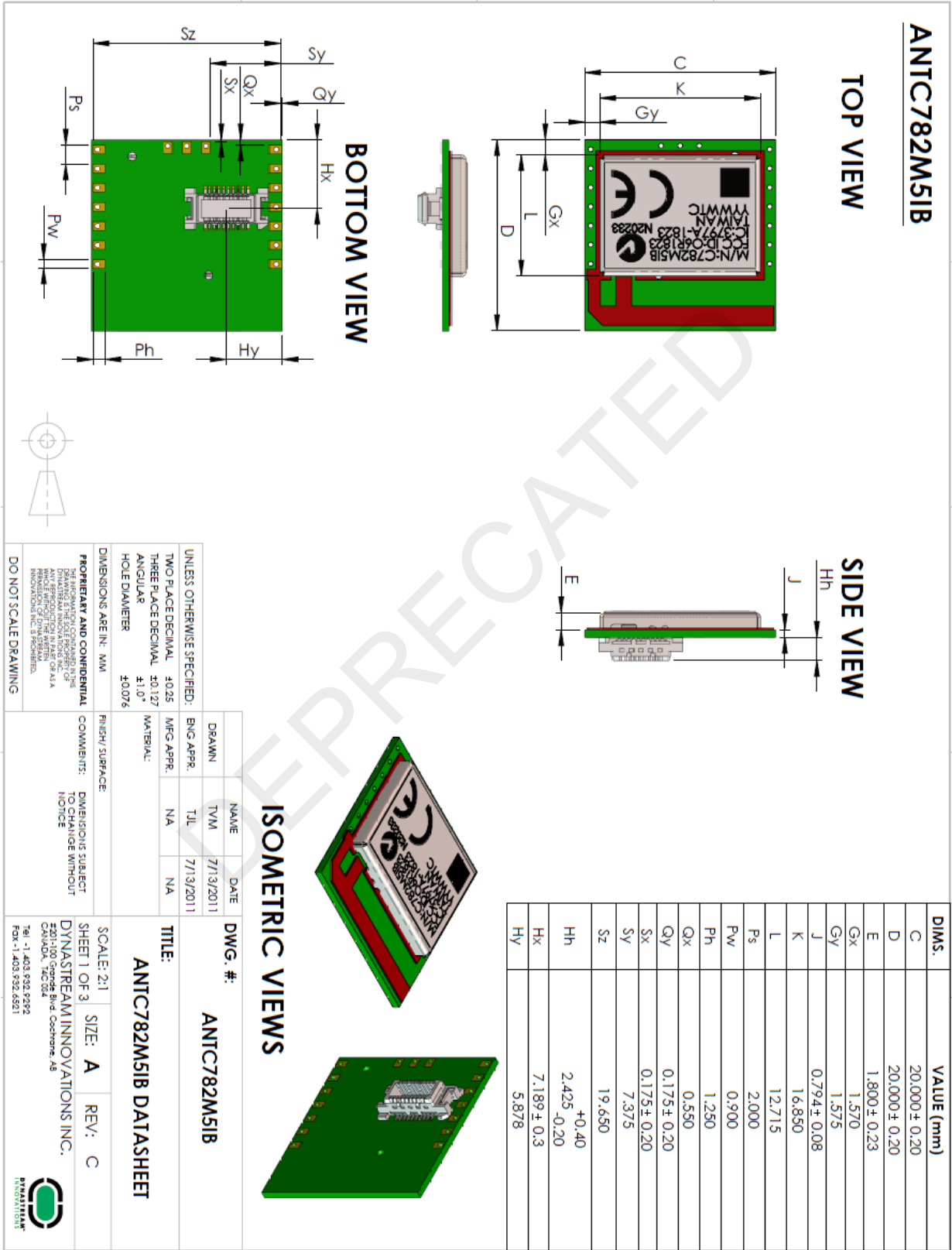



NOTES:

1. AVOID PLACING METAL COMPONENTS NEAR THE PRINTED ANTENNA OF THE C7 MODULE. HAVING METAL OBJECTS/LARGE GROUND PLANES IN THIS AREA CAN REDUCE THE RF PERFORMANCE.
2. ANTC782M51B (DEVELOPMENT) MODULES COME WITH A STANDARD MOLEX HEADER
 - C7 MALE HEADER IS MOLEX P/N 537480208
 - MATING FEMALE HEADER IS MOLEX P/N 529910208
 - ANGLED FEATURE ON HEADER DOES NOT VISUALLY REPRESENT PIN 1. FOLLOW PINOUT ON RIGHT FOR PIN NUMBERING AND ORIENTATION.

PINOUT (BOTTOM VIEW)

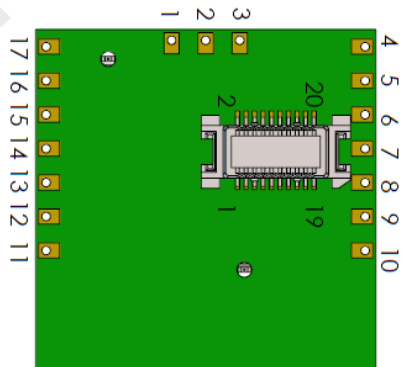

DWG. #: ANTC782M51B
SCALE: A1 SIZE: B REV: C
SHEET 2 OF 3

ANTC782M41B

TOP VIEW

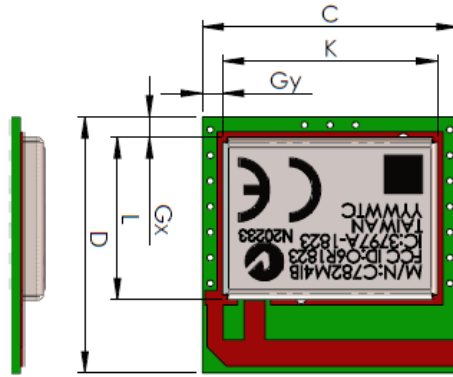

SIDE VIEW

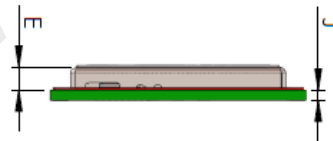

BOTTOM VIEW

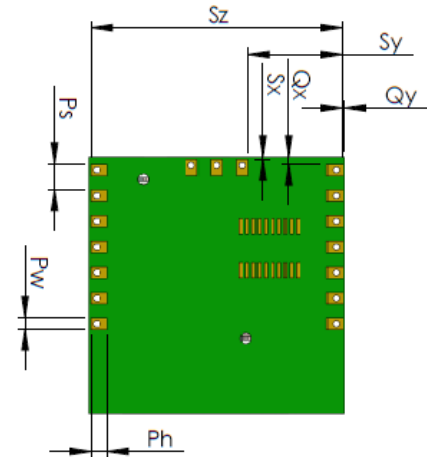

DIMS.	VALUE (mm)
C	20,000 ± 0.20
D	20,000 ± 0.20
E	1,800 ± 0.23
Gx	1,570
Gy	1,575
J	0,794 ± 0,08
K	16,850
L	12,715
Ps	2,000
Pw	0,900
Ph	1,250
Qx	0,550
Qy	0,175 ± 0,20
Sx	0,175 ± 0,20
Sy	7,375
Sz	19,650

ISOMETRIC VIEWS

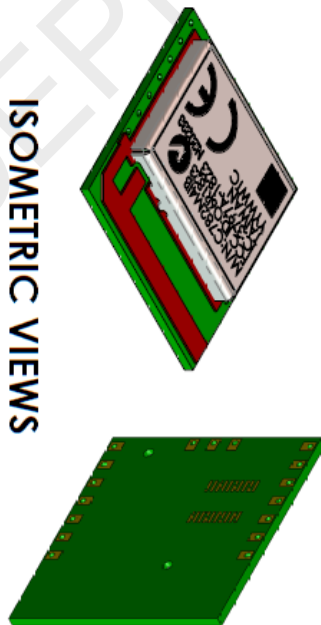

UNLESS OTHERWISE SPECIFIED:	NAME	DATE	DWG. #:
TWO PLACE DECIMAL	DRAWN	7/20/2011	ANTC782M41B
THREE PLACE DECIMAL	ENG APPR.	TJL	
ANGULAR			
HOLE DIAMETER			

PROPERTY AND CONFIDENTIAL	FLUSH/SURFACE:	COMMENTS:	DIMENSIONS SUBJECT TO CHANGE WITHOUT NOTICE
THE INFORMATION CONTAINED HEREIN IS THE PROPERTY OF DYNASTREAM INNOVATIONS, INC. AND IS NOT TO BE REPRODUCED OR TRANSMITTED IN ANY FORM OR BY ANY MEANS, WITHOUT THE WRITTEN PERMISSION OF DYNASTREAM INNOVATIONS, INC.			

SCALE: 2:1	SIZE: A	REV: C
SHEET 1 OF 3		

TITLE: ANTC782M41B DATASHEET

DYNASTREAM INNOVATIONS, INC.
 221100 CIRCLE Blvd
 CHANDLER, AZ 85226
 Tel: 1-403-932-9292
 Fax: 1-403-932-6921





- NOTES:**
1. AVOID PLACING METAL COMPONENTS NEAR THE PRINTED ANTENNA OF THE C7 MODULE. HAVING METAL OBJECTS/LARGE GROUND PLANES IN THIS AREA CAN REDUCE THE RF PERFORMANCE.
 2. ANTC782M41B MODULES COME IN A TAPE AND REEL PACKAGE FOR SMT.

PINOUT (BOTTOM VIEW)

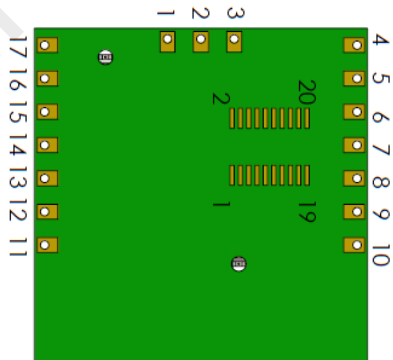

DWG. #:	ANTC782M41B
SCALE: A1	SIZE: B
SHEET 2 OF 3	REV: C

RECOMMENDED SURFACE MOUNT FOOTPRINT FOR MATING C782M41B

MATING PCB NOTES:

1. THE GROUND PLANE SHOULD BE EXTENDED TO THE FULL SIZE OF THE MATING PCB, WITH THE EXCEPTION OF THE COPPER KEEP-OUT.
2. IT IS BEST TO POSITION THE C7 SO THAT THE COPPER KEEP-OUT IS ON THE EDGE OR OVER HANGING THE EDGE OF THE MATING PCB. IF THE COPPER KEEP-OUT LAYER IS COMPLETELY WITHIN THE BOUNDARIES OF THE PCB, THE GROUND PLANE SHOULD NOT FULLY SURROUND THE COPPER KEEP-OUT. IF THIS IS NOT POSSIBLE, THE COPPER KEEP-OUT SHOULD BE MADE MUCH LARGER TO PREVENT RF DEGRADATION.
3. WHEN DETERMINING THE REQUIRED FOOTPRINT FOR FEMALE HEADER (MOLEX P/N 5297102801), USE THE SUGGESTED FOOTPRINT PROVIDED BY THE COMPONENT MANUFACTURER.

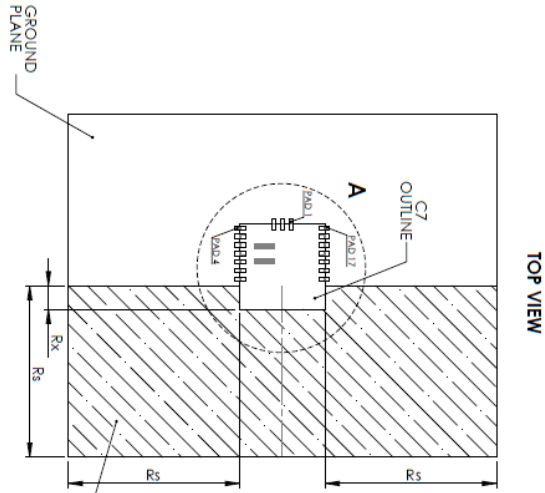

COPPER KEEP-OUT: PLACE NO COMPONENTS, COPPER OR GROUND PLANES IN THIS AREA (ALL LAYERS)

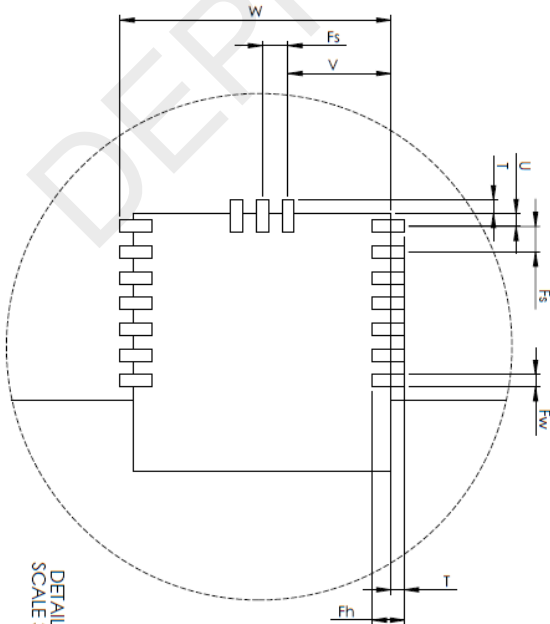

DIMS	VALUE (mm)
R _s	40.00 min
R _x	5.50
T	1.07
U	1.00
V	8.00
W	21.07
F _w	0.95
F _h	2.50
F ₃	2.00

SIZE	B	DWG. NO.	ANTC782M41B	REV.	C
SCALE	1:1	SHEET	3	OF	3

5. Technical Support

The C7 module takes the reference design of CC2571 from Texas Instruments. Users can seek technical support, esp. about hardware, from Texas Instruments, www.ti.com. Users can also seek application support from Dynastream Innovations, www.thisisant.com.

5.1 ANT Forum

Users are encouraged to participate in the ANT forum moderated by the application engineering team of Dynastream Innovations for any engineering discussions. Joining the ANT forum is free and open at <http://www.thisisant.com/forum>.

5.2 Public Technical References

Documents:

1. CC2570/CC2571 Datasheet, Texas Instruments
2. ANT Message Protocol and Usage, Dynastream Innovations
3. Integrated ANT-FS Interface Control Document
4. Interfacing with ANT General Purpose Chipsets and Modules, Dynastream Innovations

Software:

6. ANTwareII – a system testing and debugging tool

The above documents are available at <http://dynastream.com/developer/c7-modules>. More resources can be found at <http://www.thisisant.com/developer/resources/downloads>.

5.3 ANT Developer's Zone

ANT development software tools, application notes, reference designs and other public resources are found in the ANT developer's zone at <http://www.thisisant.com/developer>.

To begin development with the ANT+ interoperability, please become an [ANT+ Adopter or ANT+ Alliance member](#) to obtain the access to the ANT+ Adopter Zone. ANT+ documents and design tools contained in the ANT+ Adopter zone include the ANT+ Device Profiles, ANT-FS specification, ANT software (PC/Mac) libraries with source code, and embedded reference designs with source code.

5.4 ANT Social Media

ANT is on the following social media,

YouTube: <http://www.youtube.com/user/ANTAlliance>

Twitter: <http://twitter.com/ANTPlus>

Facebook: <https://www.facebook.com/pages/ANT/145243832297767>

LinkedIn: <http://www.linkedin.com/groups?gid=1379137>